

Description

The ISL3158AE is a 5V based RS-485 MIL temp rated transceiver aimed at addressing applications that require high operating temperatures. The receiver inputs A and B are presented in pins 6 and 7; when RE# is low this differential input signal is processed and available at the RO pin. The Driver input is presented at pin 4 and the driver differential outputs Z and Y are available at pins 6 and 7 respectively when DE is high. This Application Note aims at characterizing the device at temperatures of +125°C through +200°C.

Device Pinout

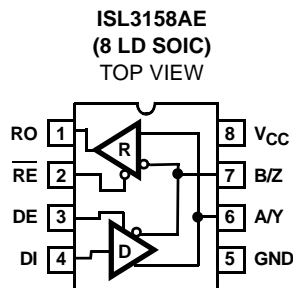

Figure 1 shows the evaluation board schematic. The device evaluation board is common to both TX and RX. The mode of operation is determined by the logic presented to the DE and RE# pins.

RX High Temperature Test

Figure 2 shows the High temperature test setup. The board wired up as the transmitter is called the EVALB TX and the one wired the receiver is called the EVALB RX. The differential lines were hooked up through 200ft of twisted pair cable terminated on either side by 120Ω. The V_{IN} was set to a worst case of 4.5V. The driver input of the EVALB TX is connected to a function generator capable of providing fast rise and fall times. The function generator output was set to provide a burst mode of five pulses at a bit rate of 10Mbps. The RX device was wired up with two thermocouples one placed on the device case top and the other placed on the PWB near the GND pin. The RX device was heated using a temperature forcing system from +25°C to +200°C. The Rx shows two threshold points as follows:

At a Data Rate of 10Mbps:

1. Pulse width 70% threshold at a die temperature of min. = +160°C and max. = +175°C while operating at a data rate of 10Mbps
2. First pulse missing Threshold at a die temperature range of min. = +175°C and a max of +191°C

At a Data Rate of 400kbps:

1. Pulse width 90% threshold at a die temp of min. = +190°C and max = +196°C while operating at a data rate of 10Mbps

As can be seen, operation at a data rate of 10Mbps limits the device operation to +160°C or less and a data rate of 400kbps allows the device to operate at a temperature of about +190°C. See “Typical Performance Curves” on page 3.

This is based on a sample size of 15pcs. and a six sigma distribution.

TX High Temperature Test

The TX was tested using a the EVALB TX portion of Figure 2. The 200ft cable was disconnected and terminations of 100Ω and 54Ω were connected based on test requirement. The parameters tested were: Driver differential output voltage, propagation delay, and skew. The results are per the “Typical Performance Curves” on page 3.

Supply Current vs High Temperature

The supply current is found to have a knee at around +195°C, and increases rapidly thereafter. The supply current with (driver enabled) DE high is typically around 650μA. This value increases to about 1085μA at +240°C. With DE connected to GND (driver disabled) the supply current drops to about 450μA typical. This value of supply current increases from a temperature of +200°C and higher to about 704.5μA.

Driver input vs High Temperature

The Driver input is found to latch to a 5V state at around +215°C. This causes the drive signal to ride on a 5V DC. The driver output is non-existent. Some device failures were observed when left in this state for prolonged period of time. See Figures 1 and 2.

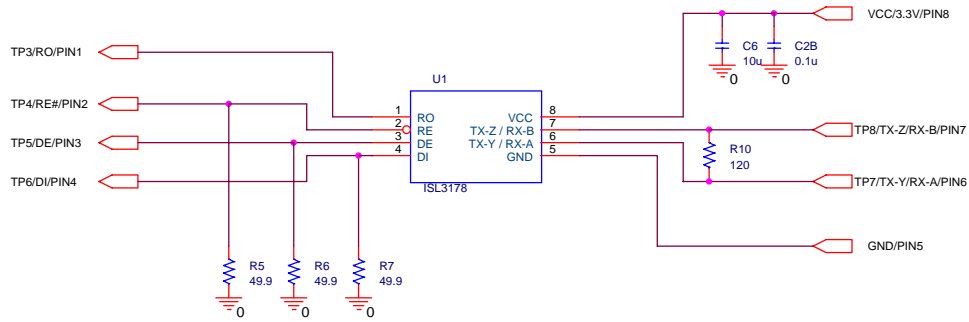

FIGURE 1. EVALUATION BOARD SCHEMATIC

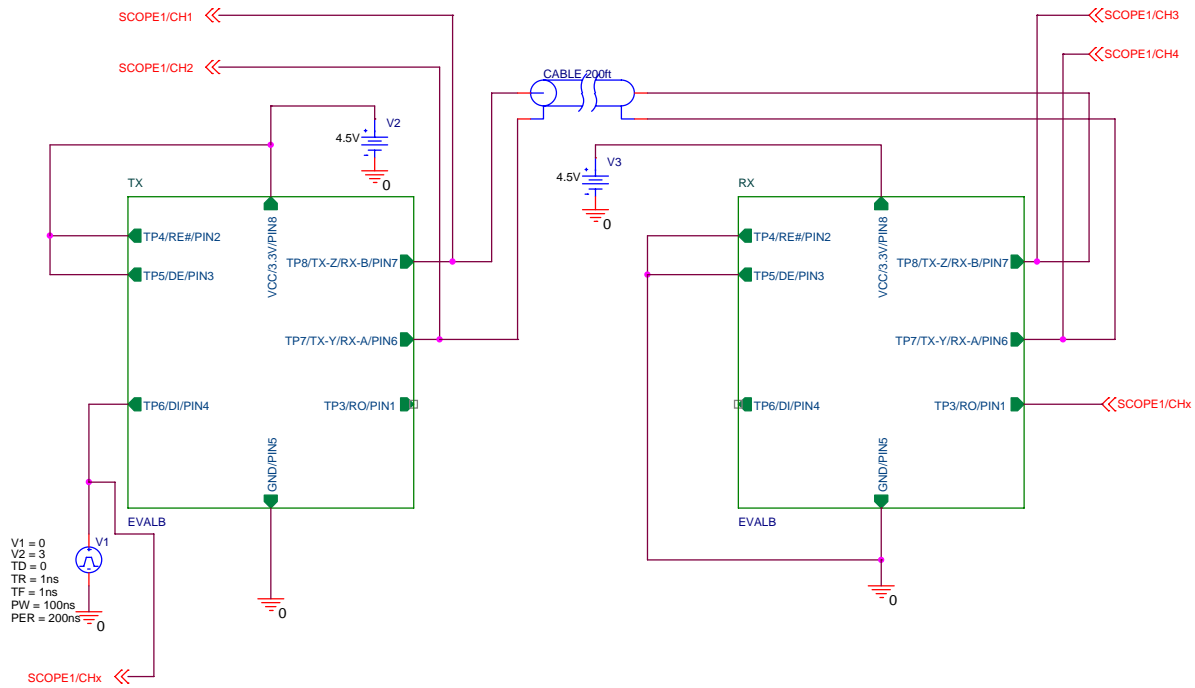

FIGURE 2. HIGH TEMPERATURE TEST SETUP

Typical Performance Curves

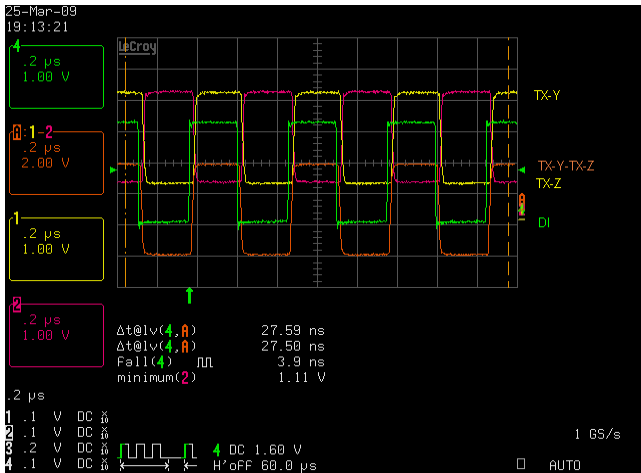

FIGURE 3. DRIVER INPUT NORMAL AT +25°C

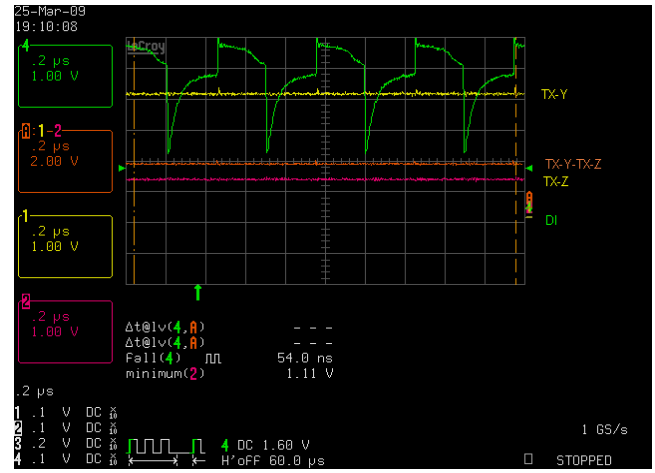

FIGURE 4. DRIVER INPUT LATCHED TO 5V AT +215°C TYP

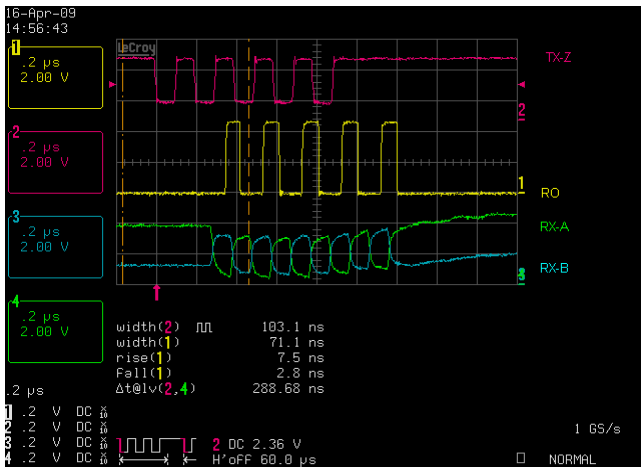

FIGURE 5. RO OUTPUT PW IS 70% AT +170.5°C TYP

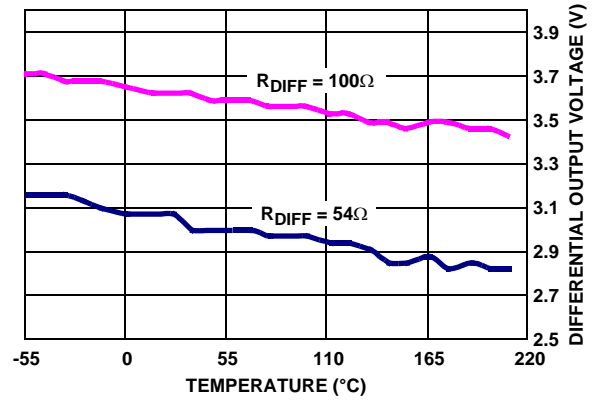

FIGURE 6. DRIVER DIFFERENTIAL OUTPUT VOLTAGE vs TEMPERATURE

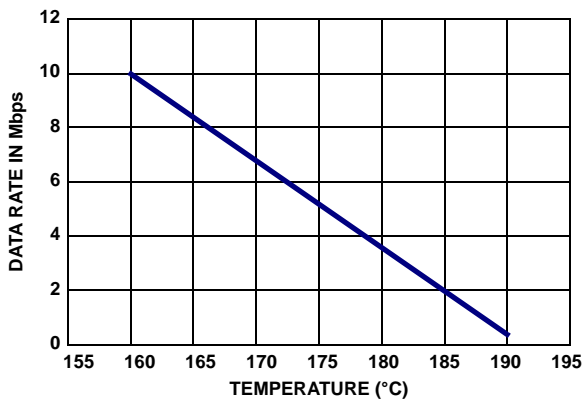

FIGURE 7. DATA RATE vs TEMPERATURE

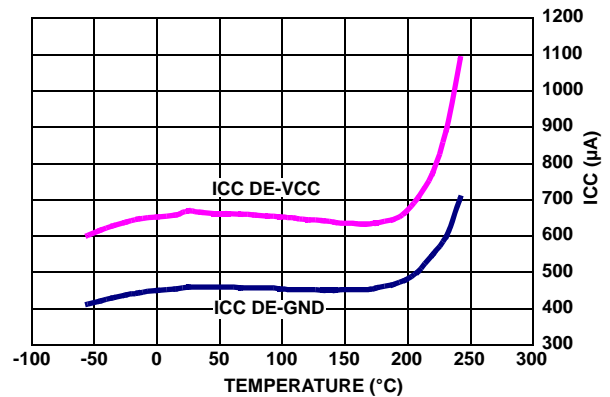

FIGURE 8. SUPPLY CURRENT vs TEMPERATURE

Typical Performance Curves (Continued)

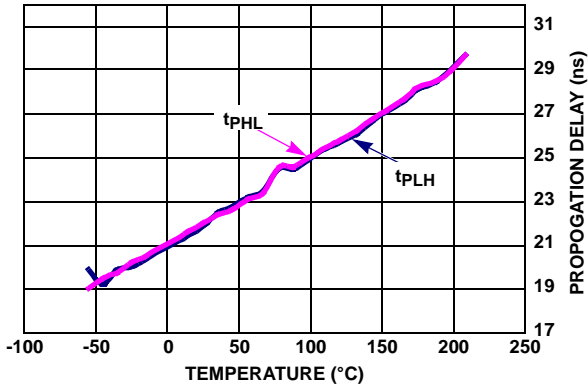

FIGURE 9. DRIVER DIFFERENTIAL PROPAGATION DELAY vs TEMPERATURE

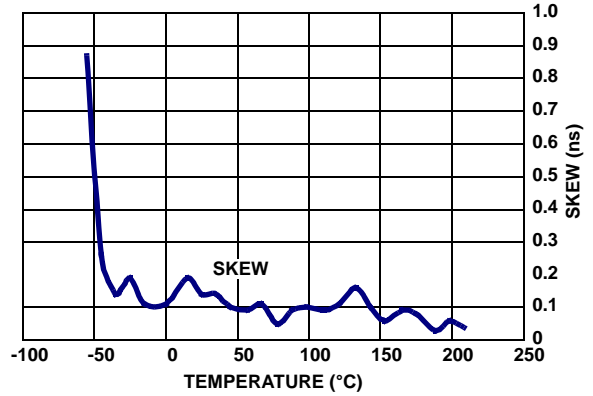

FIGURE 10. DRIVER DIFFERENTIAL SKEW vs TEMPERATURE

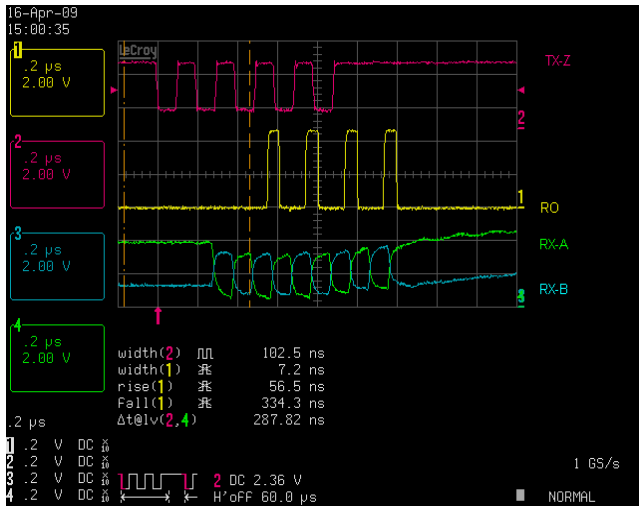

FIGURE 11. PULSE MISSING AT +185°C TYP AND 10Mbps

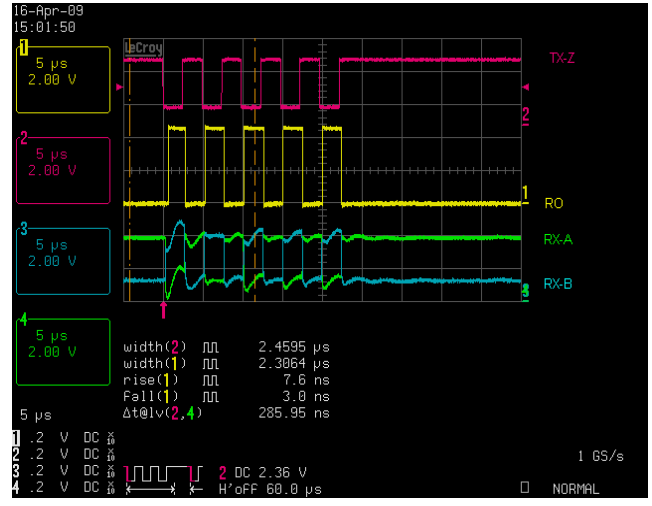

FIGURE 12. TX/RX WAVEFORM AT +194°C TYP AND 400kbps

Intersil Corporation reserves the right to make changes in circuit design, software and/or specifications at any time without notice. Accordingly, the reader is cautioned to verify that the Application Note or Technical Brief is current before proceeding.

For information regarding Intersil Corporation and its products, see www.intersil.com